

Comfort --- **plus™**

Air Filter Compartment

Model Number

ACM/ACB

With Media Filter

ACM1000

ACM1400

ACM1600

ACM2000

No Media Filter

ACB1000

ACB1400

ACB1600

ACB2000

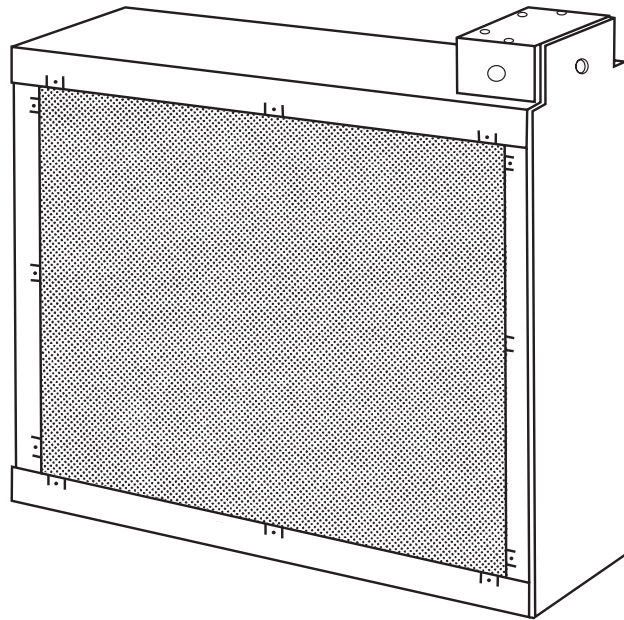

OWNER'S MANUAL

- Installation
- Operation
- Technical Repair Guide
- Repair and Upgrade Parts

Please read and familiarize yourself with the contents of this manual before installing, operating or performing maintenance on the unit.

INTRODUCTION

The White-Rodgers Air Cleaner Compartment comes complete with a 5" media furnace air filter. This filter must be changed every three months to maintain efficiency of the filter and furnace system. For maximum efficiency, the compartment can be upgraded to a White-Rodgers Electronic Air Cleaner.

Please read instructions before installing and using the Air Filter Compartment.

⚠ CAUTION

The fiber filter used in this cabinet for air cleaning must be replaced every 90 days. Your heating and cooling efficiency will decrease due to insufficient air flow when filter becomes dirty.

⚠ WARNING

Do not attempt installation of this unit unless you are familiar with the necessary tools, equipment, and potential hazards.
Installation should be performed only by a qualified service provider.
Failure to do so could result in reduced performance of the unit, serious personal injury or death.

GUARANTEE

White-Rodgers will not assume any responsibility for component failures due to incorrect installation procedures.

RULES FOR SAFE INSTALLATION AND OPERATION

1. Read the Owners Manual and the Rules for Safe Operation carefully. Failure to follow these rules and instructions could cause a malfunction of filter or unsatisfactory service.

⚠ WARNING

Installation of this unit must comply with local electric codes or other applicable codes.
Review and understand local codes prior to installation.

⚠ WARNING



Before installing or servicing, always shut off electricity. This will prevent any electrical shocks.

2. Follow a regular service and maintenance schedule for efficient operation.

TABLE OF CONTENTS

Rules for Safe Installation and Operation	2
How the Air Filter Works	3
Construction of the Air Filter Compartment	3
Preinstallation	4
Installation	6
Maintenance	7
Repair and Upgrade Parts	7

DID YOU GET THE RIGHT SIZE AIR FILTER COMPARTMENT

Model ACB & ACM1000 are designed for heating or cooling blowers delivering 600 to 1200 cubic feet of air per minute (cfm.)

Model ACB & ACM1400 are designed for heating or cooling blowers delivering 1000 to 1600 cfm.

Model ACB & ACM1600 are designed for heating or cooling blowers delivering 1200 to 1800 cfm.

Model ACB & ACM2000 are designed for heating or cooling blowers delivering 1600 to 2200 cfm.

Before installing the filter, make sure you have selected the proper size unit for your heating and cooling system requirements. See specifications on page 4.

BASIC TOOLS REQUIRED

- Tin Snip
- Screwdriver
- Rule or Tape Measure
- Drill

HOW THE AIR FILTER WORKS

Dirty air flows through your return air ducts and enters the compartment where particles (hair, lint, etc.) are removed by the filter. See figure 1.

Filtered air re-enters to the supply duct system of your building.

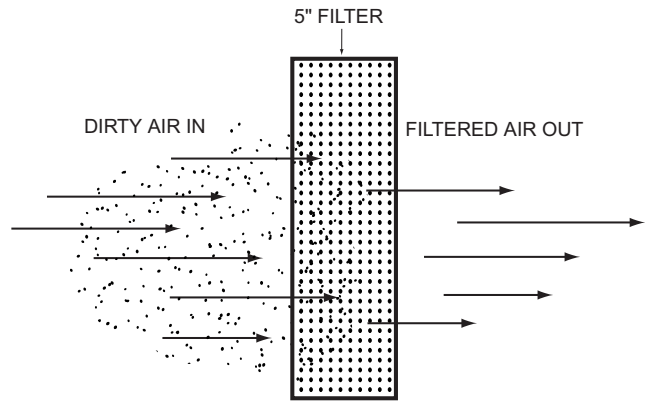

Figure 1

CONSTRUCTION OF THE AIR FILTER COMPARTMENT

Not only is your air filter compartment easy to install, it is also easy to maintain. Its basic components, and their functions, are as follows: (See Figure 2)

Air Filter Compartment- mounts to existing duct work and houses the filters or optional electronic air cleaner cells.

NOTE: To upgrade your air filter compartment with a high efficiency Electronic Air Cleaner, use the ACR (Air Cleaner Retrofit) Kit for your model. See page 7 for details.

5" Filter - collects dust, dirt and other particles.

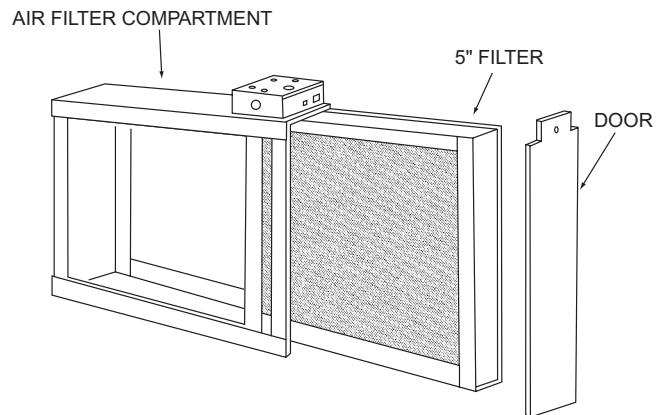

Figure 2

PREINSTALLATION

LOCATING THE AIR FILTER

Your air filter must be mounted in the return air duct of a central forced-air system, on the air entering side of your furnace. (See Figure 3 for example.)

Select a location that meets the following:

1. The face of the filter will be at a right angle to the air stream.
2. Allow 25" of clearance in front of the air filter compartment door to permit removal of filters.
See figure 4 for complete compartment dimensions.
3. The air filter is not to be placed in the discharge of either the heating or cooling unit.
4. **IMPORTANT:** If atomizing spray type humidifier is used, it must be installed downstream from the air filter.

If furnace opening cannot be enlarged to required size, a transition sheet metal section must be used. Transition must be planned for each job. Reduction should not be more than 4 inches per linear foot, approximately 20 angular degrees (Figure 3).

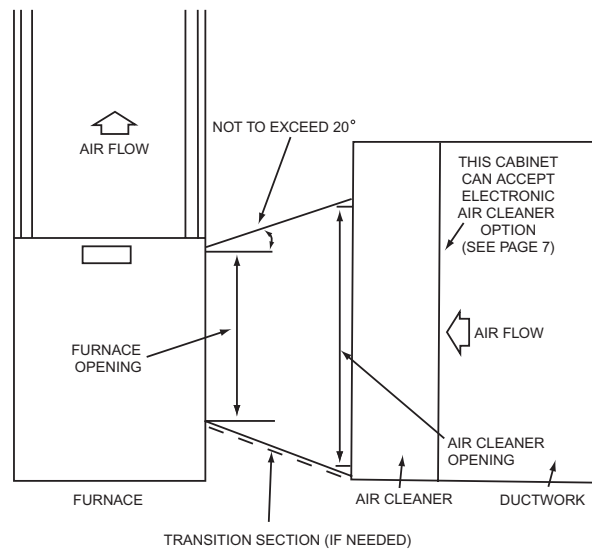
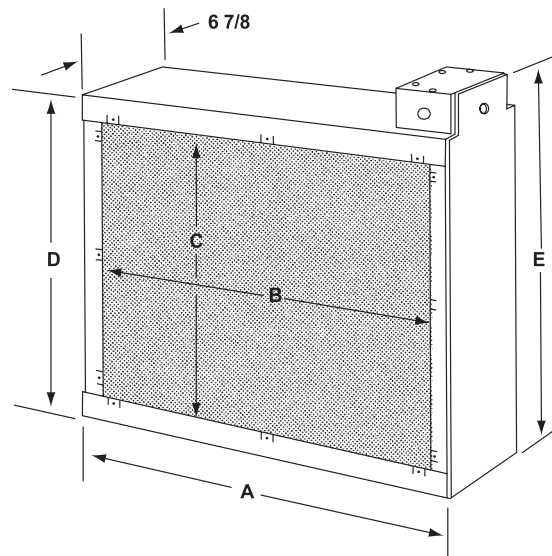

Figure 3



Model No.	A	B	C	D	E
ACB/ACM1000	20-1/4	12-5/8	13-9/16	16-7/16	19-1/16
ACB/ACM1400	26-1/4	23-5/8	13-9/16	16-7/16	19-1/16
ACB/ACM1600	20-1/4	12-5/8	17-3/4	20-5/8	23-3/8
ACB/ACM2000	26-1/4	23-5/8	17-3/4	20-5/8	23-3/8

Figure 4

TYPICAL MOUNTING POSITIONS

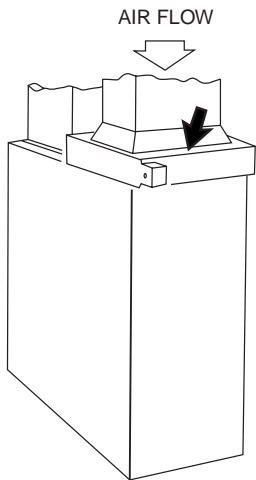

Figure 5

BASEMENT FURNACE (LOWBOY) (Figure 5)

Filter is mounted horizontally in return plenum, just above furnace.

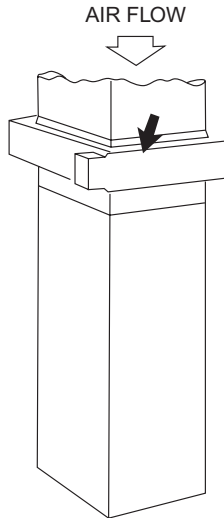

Figure 6

COUNTERFLOW FURNACE (Figure 6)

Filter is mounted horizontally in return duct or plenum, just above furnace.

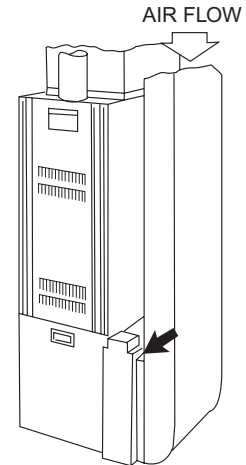
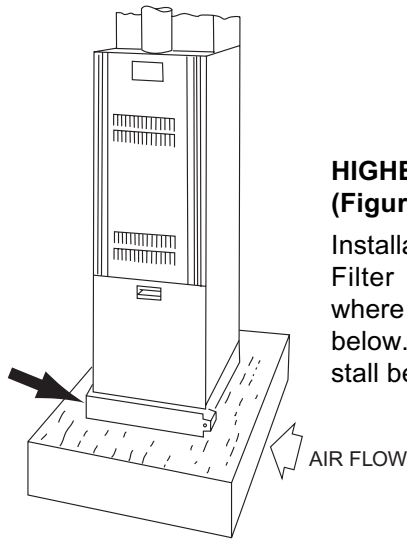

Figure 7

HIGHBOY FURNACE (Figure 7)

Side installation. Filter is mounted vertically, where return air enters side inlet of furnace.



HIGHBOY FURNACE (Figure 8)

Installation beneath furnace. Filter mounts horizontally, where return air enters from below. Raise furnace and install beneath base.

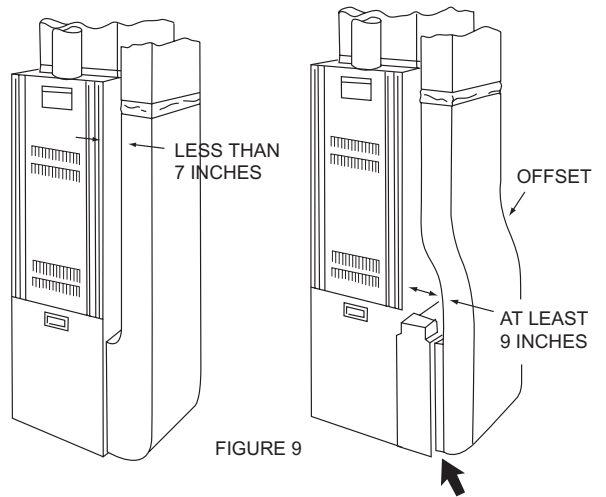

FIGURE 9

OFFSET INSTALLATION (Figure 9)

Typical use of duct offset to match air filter opening. If duct connection to furnace allows less than nine inches for mounting the air filter, shorten the lateral trunk, or attach an offset fitting to the elbow.

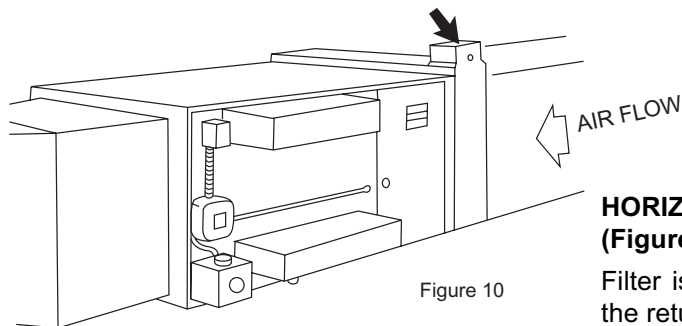

Figure 10

HORIZONTAL FURNACE (Figure 10)

Filter is mounted vertically in the return duct near furnace.

INSTALLATION

REMOVE OLD FILTER AND DISCARD (Figure 11)

NOTE: This filter may be mounted in the furnace compartment.

CLEAN BLOWER COMPARTMENT

NOTE: The air filter cannot remove dirt from blower and ducts.

INSTALLATION

The following is a typical installation of the air filter on a "Highboy" furnace (Figure 7).

1. Place the air filter compartment on the floor. Stand it upright with the door facing you (Figure 2). If a horizontal installation is being planned, lay the compartment on its side, this will help you to visualize the relative location of all parts.
2. Unscrew the knob, remove the door (by grasping top and pulling door away from compartment) and set it aside. Remove 5" filter. Set in a safe location until the compartment is installed.
3. Set the compartment next to the furnace (if possible) to match the opening in the compartment.

If the furnace opening cannot be enlarged, a transition fitting should be used. (Figure 3).

The compartment can be attached directly (Figure 12), or a starting collar can first be fitted to the furnace inlet. A butt or slip joint can be used.

Securely attach the compartment to furnace inlet, using at least two of the mounting holes on each side of the compartment.

4. Using butt joint, attach duct work (normally an elbow) to the upstream side of air filter compartment. (Note the use of the sheet metal turning vanes inside the elbow to improve air distribution.) (Figure 13)

NOTE: An optional method of attaching duct work to the air filter cabinet is to modify the compartment (Figure 14) by bending the tabs outward at a 90° angle and attaching duct work to tabs.

Transition Fittings

If the air duct does not fit the compartment opening, a transition fitting should be used. Gradual transitions are preferred for greatest efficiency. Not more than four inches per linear foot (approximately 20° angle) should be allowed (Figure 3).

5. Connect the vertical duct section to the elbow. Wedge a wood block between floor and elbow for support (Figure 15).
6. Seal all joints in the return air system downstream from the air filter with duct tape to prevent dust from entering the air stream. Tape is usually applied on the outside of ducts, but may also be applied on the inside, or both.

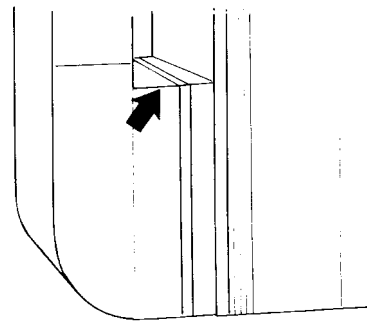

Figure 11

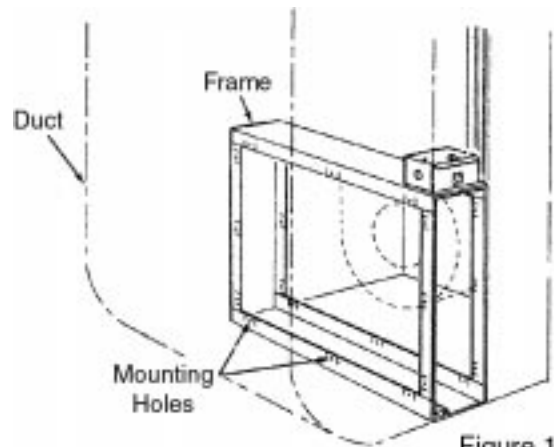

Figure 12

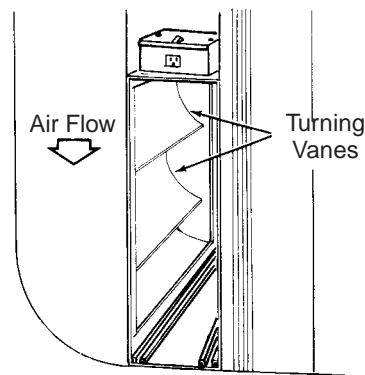

Figure 13

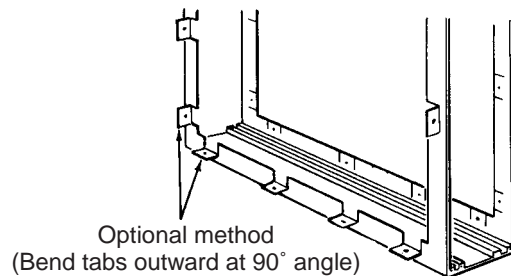

Figure 14

7. With the air filter compartment installed, re-install 5" filter and door. (Figure 2)

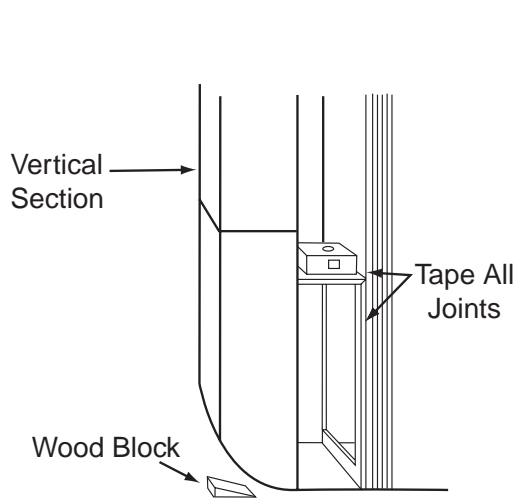

Figure 15

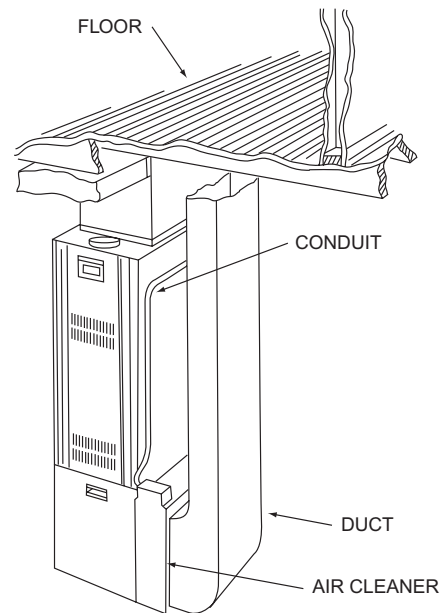

Figure 16

MAINTENANCE

CAUTION

The fiber filter used in this compartment for air cleaning must be replaced every 90 days. Your heating and cooling efficiency will decrease due to insufficient air flow when filter becomes dirty.

For maximum efficiency, your air filter should be inspected once a month and changed if dirt loading is heavy. When changing is required, the following procedure should be used:

1. Remove door from air filter compartment by unscrewing the knob.
2. Remove 5" filter and throw away.
3. Replace 5" filter by sliding it into the compartment. (Note direction of air flow.)
4. Replace door.

REPAIR and UPGRADE PARTS

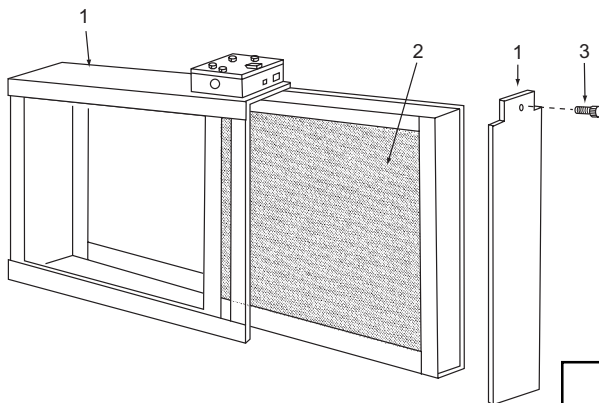

UPGRADE!



ELECTRONIC AIR CLEANER KIT

PARTS LIST FOR AIR FILTER COMPARTMENT

When ordering repair parts, always give the following information as shown in this list.

1. The PART NUMBER
2. The PART DESCRIPTION
3. The MODEL NUMBER of the Air Filter Compartment

**Always order by "PART NUMBER" . . .
Not by "ITEM NUMBER"**

Item No.	Description	Part Number			
		1000	1400	1600	2000
1	Compartment & Door	ACB1000	ACB1400	ACB1600	ACB2000
2	Filters 5"	FR1000	FR1400	FR1600	FR2000
3	Screw, Fastener	F870-0026	F870-0026	F870-0026	F870-0026

Description	1000	1400	1600	2000
Electronic Air Cleaner Retrofit Kit	ACR1000	ACR1400	ACR1600	ACR2000

NOTICE TO CONSUMERS

White-Rodgers Electronic Air Cleaner

Dear Consumer;

White-Rodgers would like to thank you for purchasing a White-Rodgers Electronic Air Cleaner or product containing a White-Rodgers Electronic Air Cleaner. Although White-Rodgers does not extend a warranty directly to consumers, White-Rodgers does extend a warranty to Wholesalers and Original Equipment Manufacturers who use White-Rodgers Products. To obtain more information about how your Wholesaler or Original Equipment Manufacturer's warranty may benefit you, please contact your Wholesaler or Original Equipment Manufacturer.

Sincerely,

White-Rodgers